

STILECHOICE[®]

by IHS Door Company

www.ihsdoor.com

TRUE STILE AND RAIL

PRIMED MDF INTERIOR DOORS

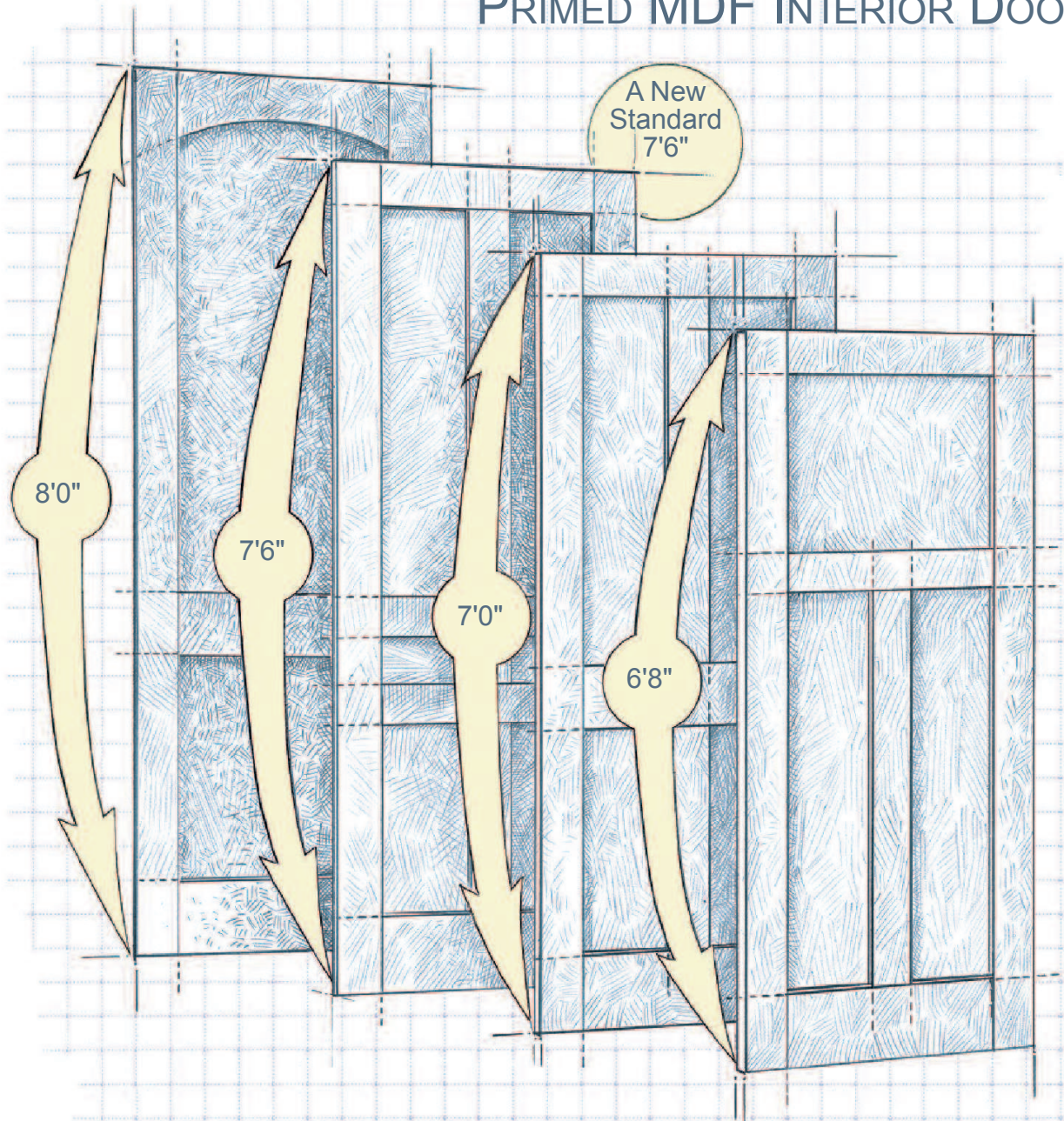

INTRODUCING DESIGN CHOICES

NOT COST LIMITATIONS

DESIGN CHOICES NOT COST LIMITATIONS

STILECHOICE® doors create new opportunities for architects, designers and interior decorators.

Given the choices of our standard offering of sizes, designs and profiles STILECHOICE® provides over 120,000 standard doors to make any project stand out. To start, we provide 7'6" height doors as standard in all designs, allowing 9'0" high ceilings to be fully appreciated without breaking budgets.

CREATIVITY UNLIMITED

If you don't see your design in our standard offering, we see another opportunity. Because when you are working with a STILECHOICE® door, we will gladly put your creativity first and deliver the custom door you desire.

STILECHOICE® doors are available in sizes up to 10' tall and 4' wide as well as options for:

- Glass
- Louvers
- Matching Wood Doors
- Custom Designs
- Match Existing Doors

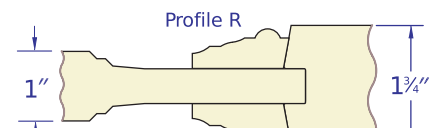
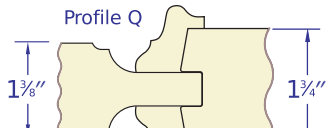
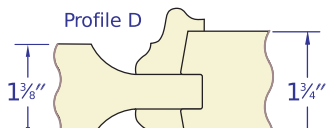
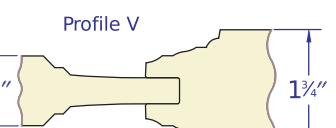
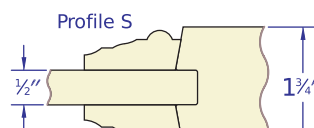
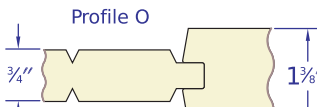
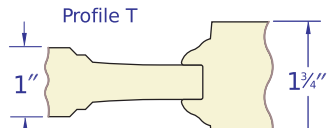
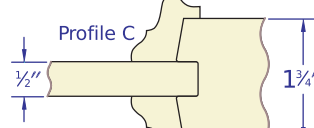
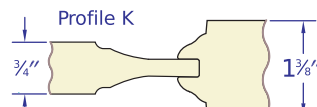
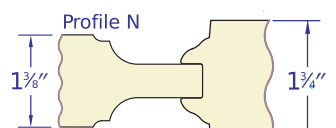
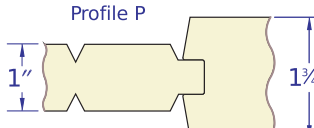
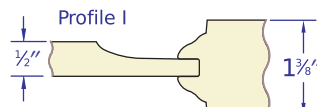
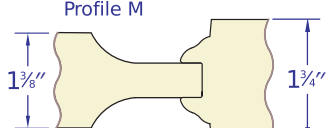
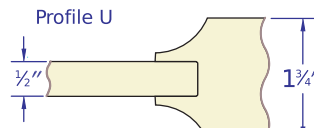
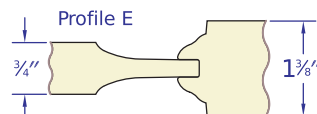
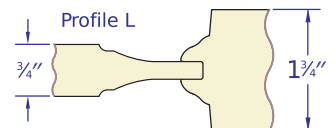
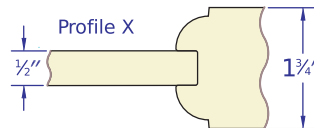
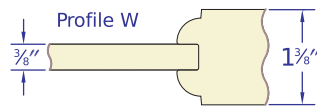
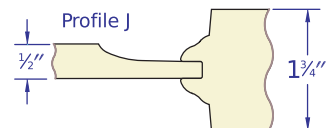
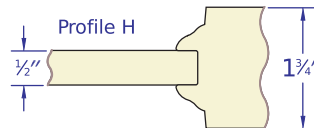
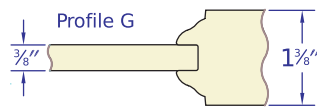
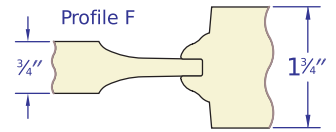
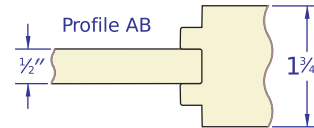
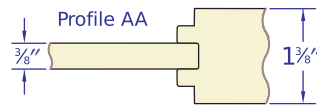
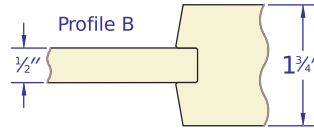
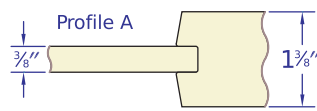

ATTENTION TO DETAIL

Our square stick design is slightly beveled to facilitate prefinishing, but retains the appearance of being square.

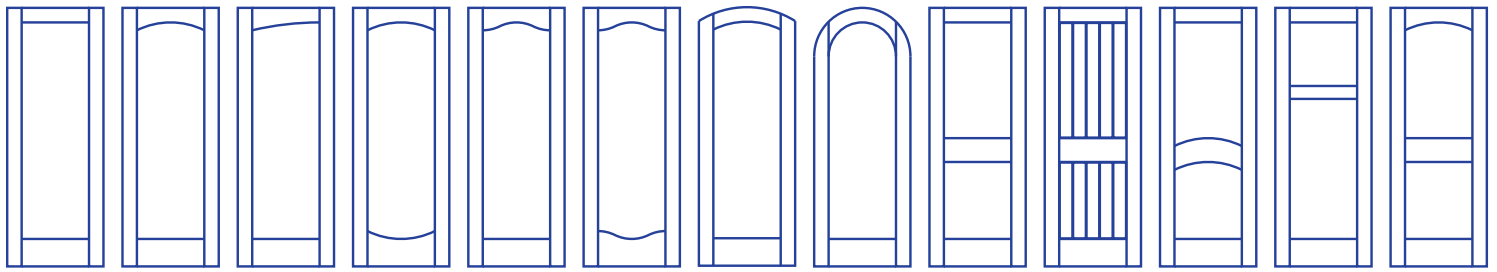

S100 A100 A102 A120 E100 E120 H100 R100 S200 S200-P S220 S221 A200

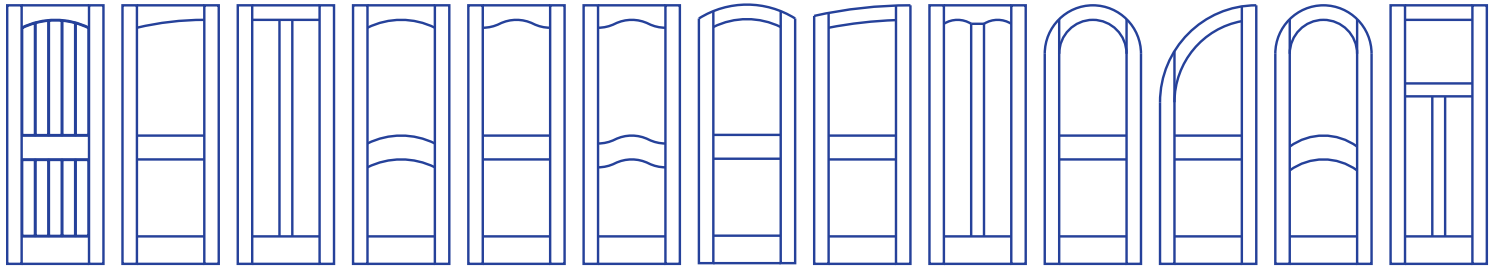

A200-P A202 S211 A220 E200 E220 H200 H202 M211 R200 R202 R220 S300

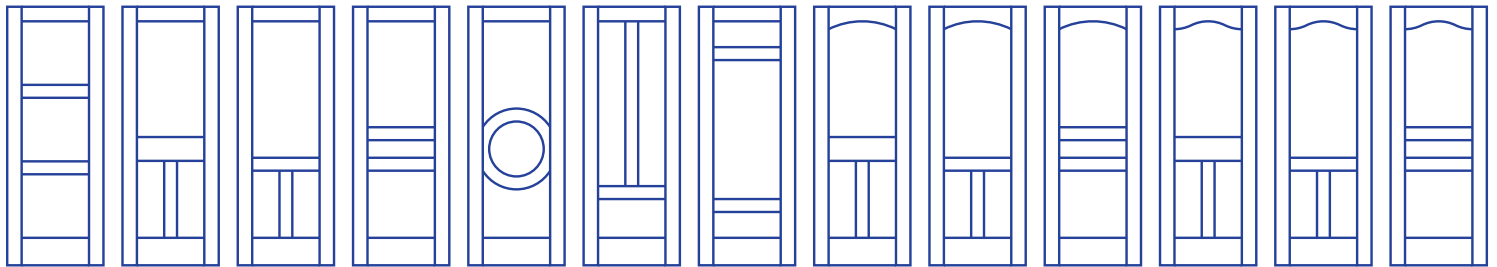

S302 S310 S312 S313 S314 S319 S323 A310 A312 A313 E310 E312 E313

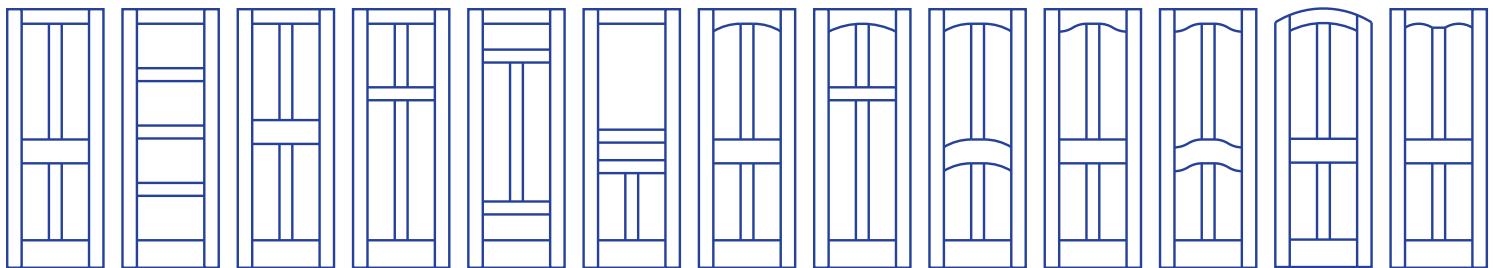

S400 S402 S404 S412 S422 S423 A400 A412 A420 E400 E420 H400 M400

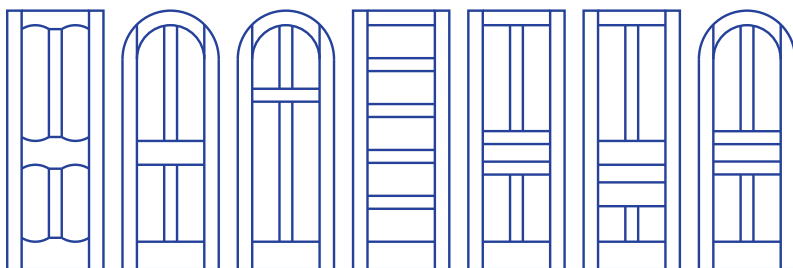

M420 R400 R412 S502 S515 S523 R515

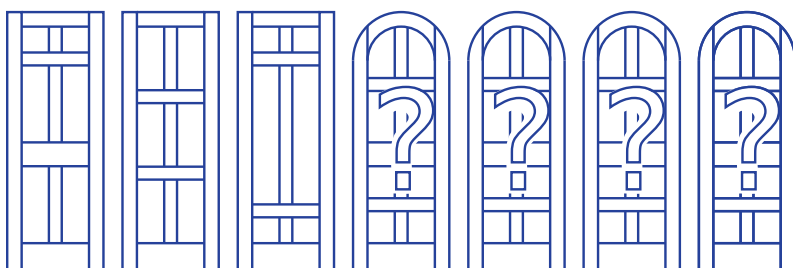

S600 S602 S610 YOUR DESIGN MAY BECOME OUR NEXT STANDARD

SPECIFICATIONS

Heights	6'8, 7'0, 7'6, 8'0, Custom to 10'
Widths	1'0, 1'2, 1'3, 1'4, 1'5, 1'6, 1'8, 1'10, 2'0, 2'2, 2'4, 2'6, 2'8, 2'10, 3'0, Custom to 4'0 *Widths under 2'0 will not have a mullion.
Bifold	1-3/8" x 6'7 x 2'0, 2'6, 3'0, and Custom

COMPONENTS

COMMERCIAL

Thickness	1-3/8"	1-3/4"	1-3/4"
Top Rail	4-1/2"	4-1/2"	5-7/8"
Cross/Mullion	4"	4"	4"
Lock Rail	7-3/8"	7-3/8"	7-3/8"
Bottom Rail	8-1/2"	8-1/2"	11-1/2"
1'0 - 1'5 Stile	3-5/8"	3-5/8"	3-5/8"
1'6 - Up Stile	4-1/2"	4-13/16"	5-7/8"

STILECHOICE®

BY IHS DOOR CO.

We are a manufacturer of green sustainable doors. STILECHOICE® doors are true stile and rail interior doors for residential and commercial installations. Our doors are made with MDF (Medium Density Fiberboard) that contains over 90% recycled wood fiber and are coated with water-based primer. As a result, we are able to deliver you doors that are dimensionally stable, paint exceptionally well, and are generally eligible for various green building standards such as LEED. Further, using water soluble paint allows doors to air-dry without creating hazardous fumes, keeping employees safe while lowering energy consumption. Since we produce our doors in the USA and our materials are not imported from overseas, you can be assured every aspect of our manufacturing process uses minimal resources. We have even designed our doors to minimize our one major by-product, sawdust, which, in the end, is used for renewable energy production.

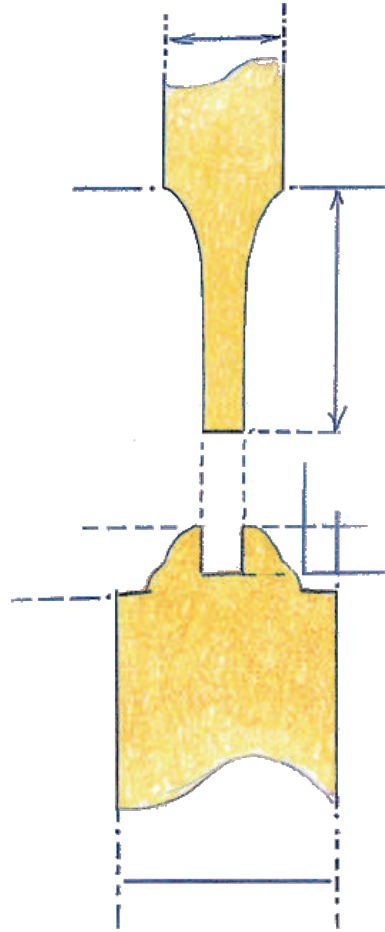

IMPORTANT INFORMATION

SCREWS: Use straight shank screws with a small root diameter and a widely spaced “aggressive” thread pattern. We recommend using a #9 x 1 1/4” for 1 3/8” doors and a #10 or #12 x 1 1/4” for 1 3/4” doors.

PRE-DRILLING AND TIGHTENING: Pilot holes are required and should be between 85% to 90% of the root diameter of the selected screw, and drilled to a depth greater than the screws driven length. Screws should not be over tightened. Set clutch on your drill to minimum. Should a minor split occur, due to over tightening, remove the screw and fill split with wood putty.

HINGES: Use 3 hinges on 6’8” and 7’0” doors and 4 hinges on 7’6” an 8’0” doors.

HANDLING: Doors should not be delivered to the job site until all other trades are complete and concrete floors, plaster and drywall are completely dry. Doors should be stored flat in a dry, well ventilated area. The doors should not be placed directly on the floor, but placed on at least three equally spaced supports (2x4 or similar). **DO NOT LEAN DOORS** up against the wall.

FINISHING: To properly finish the door use a high quality paint and apply it in strict accordance with the manufacturer’s specifications. Be sure to patch any minor dents or scratches that have occurred during handling. Do any required final sanding and be sure to wipe the door clean before applying any paint. Doors are to be finished on both sides and all four edges. **DO NOT LEAVE ONE SIDE UNFINISHED** for a prolonged period of time. When finishing the doors both sides should be finished at the same time.

WARRANTY

2 years for manufacturing defects.

Visit www.ihsdoor.com to view the full warranty, download a PDF version, or contact your distributor for a copy.

STILECHOICE®
by IHS Door Company

www.ihsdoor.com

1505 North 8th Street
Superior, WI 54880

sales@ihsdoor.com

715.392.8102
715.392.8128 fax

Distributed By:

